

MACHINERY RANGE

Reach stackers

- _ Loads from 10 to 90 t



General load Lift Trucks

- _ Light duty range from 8 to 15 t
- _ Medium duty range from 16 to 25 t
- _ Heavy duty range from 28 to 60 t



Lift Trucks for containers

- _ For laden containers from 32 to 50 t
- _ For unladen containers from 3 to 8 heights
- _ Containers standard handling
- _ Containers longitudinal handling



Spreaders

- _ Telescopic from 20 to 45'
- _ Fixed
- _ Intermodal handling (Piggy- back)



UP LIFTING VERTICAL, S.A.

Ronda de la Industria, Parc 151. Pol. Sepes. 22006
Huesca
Tel. 974 229 832 Fax. 974 242 481
uplifting@gaypu.com

www.uplifting.es

9-4400E-01-16-002-0



TUP 25-1200-SP

Forklift for general loads
25t (1200mm) to 35t (500mm)



New ways to advance without pause, **step by step...**

TUP 25-1200-SP

Forklift for general loads. From 25t (1200mm) to 35t (500mm)

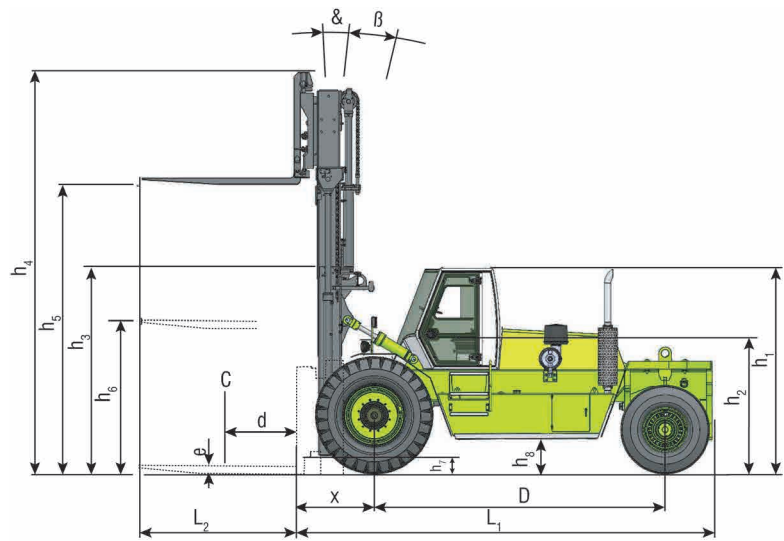

Dimensions (mm)

OVERALL

Length L ₁	6600
Distance between axles D	4600
Distance between wheels:	
_Centres of front axle A ₁	2200
_Centre of back axle A ₂	2200
Total width A ₃	2860
Truck height h ₁	3250
Seat height h ₂	2450
Height of cab at max. side shift	4050
Width of cab at max. side shift	3750
Distance of the load x	1280
Load centre d	1200

MAST

Minimum height h ₃	3300
Maximum height h ₄	6400
Height lift h ₅	4600
Free lift h ₆	1600
Tilt angle	
_Forwards &	5°
_Backwards β	10°

FORKS

Thickness e	110
Width A ₄	300
Length L ₂	2400
Max distance between forks D ₁	2250
Min distance between forks D ₂	940
Maximum side-shift	+/- 500

TURNING RADIUS

Outer R ₁	6100
Inner R ₂	600

Environment

- _ Lowering toxic emissions engine in accordance with Stage IV/Tier 4f.
- _ The use of high elasticity steel ensures the diminution of harmful emissions to the environment.

Toughness

- _ Large sections made of high strength steel.
- _ Critical resistant elements get a visual and a controlled testing inspection once welded.
- _ A latest generation welding robot is used for welding.

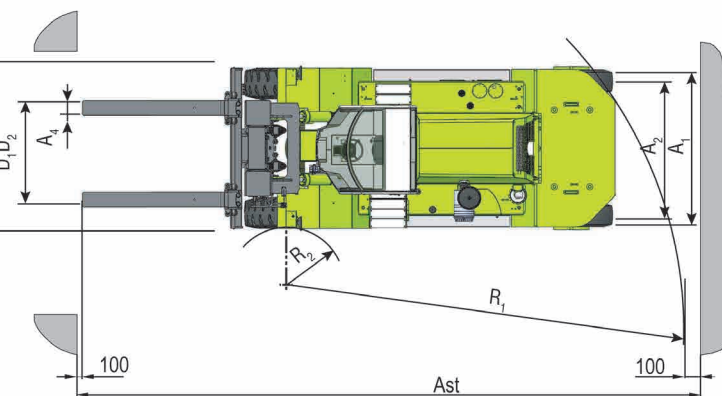

GROUND CLEARANCE

Under Mast H ₇	300
At centre of distances between axles H ₈	460

Cab

- _ Excellent visibility all around: ISO/DIS 13564-1
- _ Operator's seat with air suspension
- _ Tinted safety glass
- _ Laterally reclining
- _ Tilting steering column
- _ Sound proofing ISO/TS 3691 - 7:2011
- _ Easy accessibility
- _ Joystick which controls mast and accessories.

Safety

- _ Safety-glass is used in the whole machine.
- _ Functions control by electronic system.
- _ Seat belt is incorporated.
- _ Non-slip steps to get the cabin.

Weights

TUP 25-1200	Unladen
Front axle	19.0 t
Rear axle	18.5 t
Total	37.5 t

Tyres

	Front	Rear
Number	2	2
Dimensions	(18.00x33)	(14.00x24)

Electronic control system

- _ 3.5" transfective TFT master color display
- _ Engine, transmission and satellite modules control
- _ External GSM modem
- _ Large internal memory for events and logging
- _ Instantaneous display of warnings

Transmission

Manufacturer	ZF
Model	3WG211

Steering

Hydraulic

Drive axle

Manufacturer	KESSLER
Model	D102PL341-NLB

Drawbar pull

Maximum	160
Maximum 2 km laden	122

Load diagram

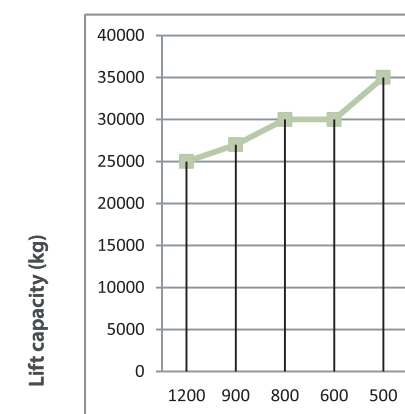

Distance to centre of load (mm) from the surface of the fork.
The lift capacity is with vertical mast.

Engine

Manufacturer	VOLVO
Model	TAD 873 VE
Power (ISO 3046/2534)	235kw
Torque	1300 N m
	1000 - 1400 rpm
Speed	2200 rpm
Cylinders	6
Displacement	7,7 L

Speeds

TUP 25-1200	Unladen	Laden
Travel	25 km/h	23 km/h
Lifting	0.27 m/s	0.25 m/s
Lowering	0.30 m/s	0.30 m/s

Brakes

Service brake	Oil bath disc brake. No maintenance is needed
Parking brake	Disc brake. Spring applied and hydraulic released.

Starter battery

Tension	2x12 V
Capacity	165 Ah

Gradeability

	2 km/h	0 km/h
Laden	18	23

Noise level

Cab	77 dB
-----	-------

Optional equipment

- _ Automatic lubrication system.
- _ Cameras system.
- _ Tyre pressure control system.
- _ Fire suppression system
- _ Fleet vehicle management (electronic control system)
- _ Air-conditioner system
- _ 2 or 3 stage mast with/without free lifting.
- _ Wide range of adjustable carriages for each feature.
- _ Integrated ram for coils or quick assembly
- _ Forks for ISO container dimensions
- _ 20' and 40' fixed spreader

Load (kg)	25000	27000	32000	32000	35000
Distance (mm)	1200	900	800	600	500
Load in the front axle (kg)	57500	58800	62500	64100	67500
Load per wheel (kg)	28750	29400	31750	32050	33750
Maximum speed (km/h)	20	10	5	3	2
Stability	1,37	1,44	1,36	1,41	1,36