



TUP 5/6-EC

Forklift for containers

Transversal load



TUP 5/6-EC

Forklift for empty containers. 5/6 containers. Transversal load. Rated capacity 8 t.

Dimensions (mm)

OVERALL	TUP-5 EC	TUP 6-EC
Length L_1	7015	7015
Distance between axles D	5000	5000
Distance between wheels:		
_Centres of front axle A_1	3260	3260
_Centre of back axle A_2	2442	2442
Total width A_3	4110	4110
Truck height h_1	4400	4400
Seat height h_2	2920	2920
Distance of the load x	1230	1230
Load centre d	1250	1250

MAST

Minimum height h_3	9050	10 450
Maximum height h_4	16 725	19 540
Height lift duplex h_5	13 950	16 750
Max.height under twistlocks h_6	16 280	19 100
Tilt angle		
_Forwards α	3°	3°
_Backwards β	6°	6°

STACKING AISLE (AST)

For containers of 20'	10 300	10 300
For containers of 40'	14 650	14 650

GROUND CLEARANCE

Under lift frame h_7	280	280
At centre of distance between axles h_8	400	400

TURNING RADIUS

Outer R_1	6400	6400
Inner R_2	170	170

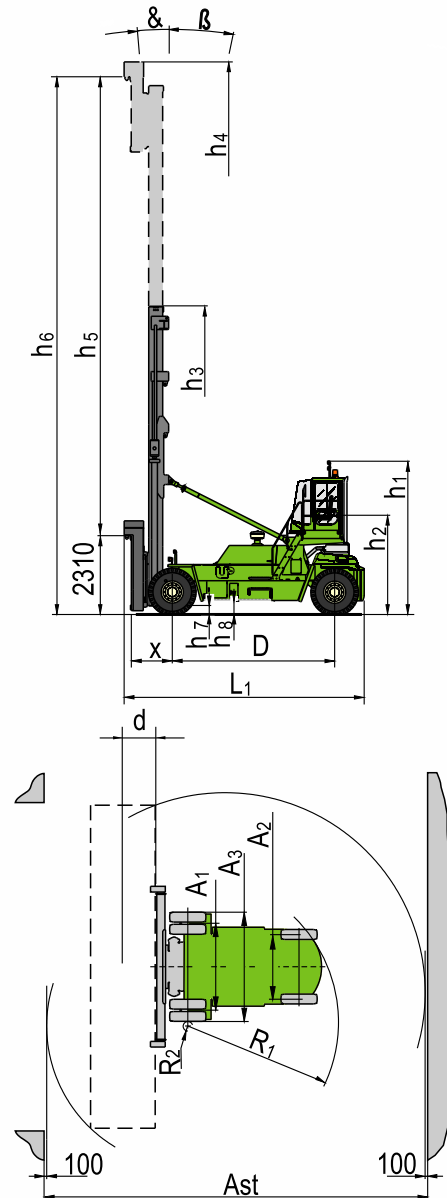

Cab

- _ Excellent visibility all around: ISO/DIS 13564-1
- _ Hydraulic reclination
- _ Operator's seat with air suspension
- _ Tinted safety glass
- _ Tilting steering column
- _ Sound proofing ISO/TS 3691 - 7:2011
- _ Accessibility
- _ Joystick to control spreader movements.

Safety

- _ Safety-glass is used in the whole machine.
- _ Functions control by electronic system.
- _ Safety belt is incorporated.
- _ Non-slip steps to get the cabin.

Environment

- _ Lowering toxic emissions engine in accordance with Stage IV/Tier 4f.
- _ The use of high elasticity steel ensures the diminution of harmful emissions to the environment.
- _ Stage II/Tier 2 or Stage IIIA/Tier 3 Engines for non-regulated regions which do not belong to the EU.

Toughness

- _ Large sections made of high strength steel.
- _ Critical resistant elements get a visual and a controlled testing inspection once welded.
- _ A latest generation welding robot is used for welding.

Weights

TUP 5-EC	Unladen	Laden
Front axle	22.7 t	35.4 t
Rear axle	15.2 t	10.3 t
Total	37.9 t	45.7 t

TUP 6-EC	Unladen	Laden
Front axle	23.3 t	35.9 t
Rear axle	14.9 t	10.3 t
Total	38.2 t	46.2 t

Speeds

TUP 5-EC	Unladen	Laden
Travel	28 km/h	25 km/h
Lifting	0.69 m/s	0.55 m/s
Lowering	0.50 m/s	0.60 m/s

Engine

Manufacturer	CATERPILLAR	VOLVO
Model	C7.1	TAD 871 VE
Power (ISO 3046/2534)	168 kw	185 kw
Torque	1092 N m	1150 N m
	1400 rpm	1400 rpm
Speed	2200 rpm	2200 rpm
Cylinders	6	6
Displacement	7010 cc	7700 cc

TUP 6-EC	Unladen	Laden
Travel	28 km/h	25 km/h
Lifting	0.65 m/s	0.60 m/s
Lowering	0.65 m/s	0.70 m/s

Tyres and wheels

	Front	Rear
Number	4	2
Dimensions	(14.00x24)/28PR	(14.00x24)/28PR

Brakes

Service brake	Wet disc brake with oil bath. No maintenance is needed.
Parking brake	Disc, Spring applied and hydraulic released

Electronic control system

- _ 3.5" transfective TFT master color display
- _ Engine, transmission and satellite modules control
- _ External GSM modem
- _ Large internal memory for events and logging
- _ Instantaneous display of warnings

Starter battery

Tension Capacity	2x12 V 165 Ah
------------------	------------------

Transmission

Manufacturer	ZF
Model	3WG211

Gradeability

Nominal 2 km/h laden	25
0 km/h laden	28

Steering

Hydraulic

Spreader

_ Uplifting model	TSEUP 24-B
_ Classification	DIN 15018, H2B4
_ Load capacity	8 t
_ Weight	3550 kg
_ Telescoped pieces	20-30-40 feet
_ Twistlocks	ISO oscillating
_ Side-shift	+/-600 mm
_ Telescoping time	20 seconds

Driving axle

Manufacturer	KESSLER
Model	D81PL488-NLB

Optional equipment

- _ Automatic lubrication system
- _ Camera system
- _ Tyre pressure monitor
- _ Fire suppression system
- _ Air-conditioner
- _ Vehicle fleet management (electronic control system)

Drawbar pull

	TUP 5 EC	TUP 6 EC
Maximum	146 kN	146 kN
Maximum 2 km laden	121 kN	121 kN

Noise level

Cabin	77 dB
-------	-------

MACHINERY RANGE

Reach stackers

- _ Loads from 10 to 90 t



General load Lift Trucks

- _ Light duty range from 8 to 15 t
- _ Medium duty range from 16 to 25 t
- _ Heavy duty range from 28 to 60 t



Lift Trucks for containers

- _ For laden containers from 32 to 50 t
- _ For unladen containers from 3 to 8 heights
- _ Containers standard handling
- _ Containers longitudinal handling



Spreaders

- _ Telescopic from 20 to 45'
- _ Fixed
- _ Intermodal handling (Piggy- back)



UP LIFTING VERTICAL, S.A.

Ronda de la Industria, Parc 151, Pol. Sepes, 22006
Huesca
Tel. 974 229 832 Fax. 974 242 481
uplifting@gaypu.com

www.uplifting.es

9-4400E-01-13-011-0